



**Tablets
Capsules
LCT's**

Up to 60,000 PPH

Delta Laser Drill

One or Two-Sided CO₂ Drill
Single-Lane Carrier Link Feed System

Delta Laser Drill

C02 Laser Drilling for Tablets & Capsules

The Delta Laser Drilling Machine can drill precision holes in tablets and canisters for osmotic controlled release oral delivery (OROS). The fully adjustable hopper allows the product to flow smoothly to the laser station and can laser drill 50,000 to 60,000 pieces per hour. The machine can detect bi-layered tablets and drill on a specific side of a tablet or canister LCT.



Features

- Single or two-sided laser drilling
- Adjustable hopper for maximum fill rate
- Servo drive system for precision print registration
- Quick change tooling
- Swingarm 15" touchscreen HMI
- Wi-Fi connectivity
- Batch recording
- 21 CFR Part 11 Compliant
- CE and UL certified

Capabilities

- Output Up to 60,000 / Hour
- Single or Double Sided Laser Drilling.
- Adjustable aperture:
 - Diameter - 0.400 to 1.500mm
 - Depth - 0.30 to 1.50mm
- Drill up to 4 apertures per side with adjustable spacing
- Color recognition system

Options

- Vision inspection system with single piece rejection
- Validation document packages available
- Floor level infeed bulk conveyor

Safety & Regulatory Compliance

- cGMP for Pharmaceuticals:
- FDA 21 CFR Compliance:
 - Part 210
 - Part 211
 - Part 11
- CE Compliant
- NFPA 79
- IEC / EN 60204-1
- ISO 13849-1
- CRC, c 870
- CDRH Compliant

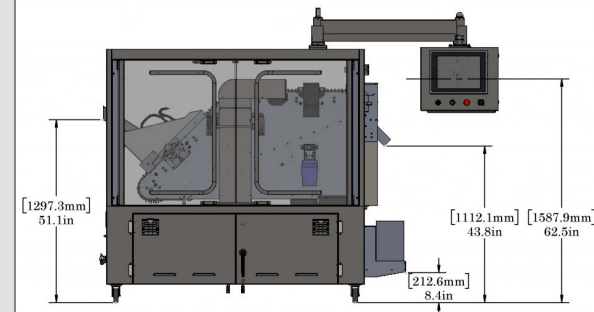
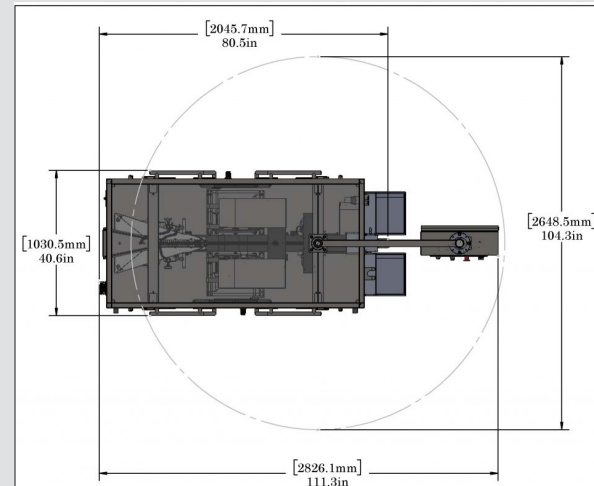

Specifications

H	2150mm / 84.6in
H1	1264.3mm / 49.8in
H2	1578.9mm / 62.2in
W1	829.2mm / 32.6in
W2	2416.4mm / 95.1in
L1	1663.5mm / 65.5in
L2	2328.5mm / 91.7in
POWER	240 VAC / 20 amp / 1 phase
AIR PSI	Air 90 psi @ 5 scfm



Made in the USA