

*Tablets
Capsules
LCT's
Softgels*

Up to 180,000 PPH

H-Track Printer

One Sided Rotogravure Printing
Bulk Hopper

H-Track Printer

Rotogravure Printing System for Tablets & Capsules

The H-Track Printing Machine is a flatbed printing machine that has the ability to ink print one side of a tablet, soft gelatin capsule, or caplet. The H-Track comes with an adjustable feed hopper for maximum fill rates and has a production output of 120,000 to 180,000 pieces per hour. The machine is equipped with a bulk hopper to maintain high production speeds.

Features

- Single sided printing
- Adjustable hopper for maximum fill rate
- Servo drive system for precision print registration
- Quick change tooling
- Swingarm 15" touchscreen HMI
- Wi-Fi connectivity
- Batch recording
- Data transfer capability
- 21 CFR Part 11 Compliant
- CE and UL certified

Capabilities

- Output Up to 180,000 / Hour
- Single Sided Printing with independent graphics for each side
- Single Sided marking using time proven rotogravure printing
- Ability to print alpha-numeric text or graphic logos
- Ability to print with solvent or water based ink solutions
- Ability to print in multiple ink colors

Options

- Vision inspection system with single piece rejection
- Ink Viscosity System
- Rubber Roll Cleaning System
- Validation document packages
- Floor level infeed bulk conveyor

Safety & Regulatory Compliance

- | | |
|-----------------------------|--------------------|
| • cGMP for Pharmaceuticals: | • NFPA 79 |
| FDA 21 CFR Compliance: | • IEC / EN 60204-1 |
| - Part 210 | • ISO 13849-1 |
| - Part 211 | • CRC, c 870 |
| - Part 11 | • CDRH Compliant |
| • CE Compliant | |

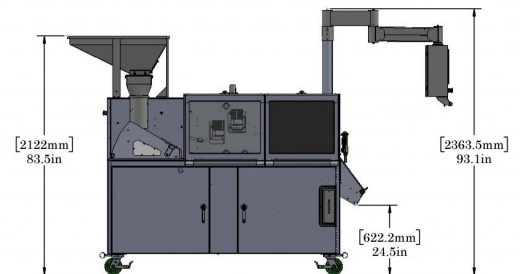
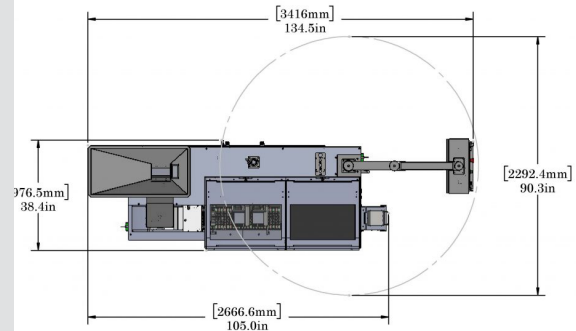

Specifications

H	1524.0mm - 1853.00mm / 60.0in - 73.0in
H1	1895.5mm / 74.6in
H2	2305.7mm / 90.8in
W1	918.3mm / 36.2in
W2	2384.6mm / 93.9in
L1	3224.4mm / 126.9in
L2	2473.8mm / 97.4in
POWER	240 VAC / 30 amp / single phase
AIR PSI	Air 90 psi @ 5 scfm



Made in the USA