



**Tablets**  
**Capsules**  
**LCT's**

**Up to 300,000 PPH**

**IBM Laser Drill**

One Sided CO2 Laser Drilling  
Bulk Hopper & Floor Feeder

# IBM Laser Drill

## C02 Laser Drilling for Tablets & Capsules

The IBM Laser Drilling Machine is our high-speed, large scale production laser drilling machine. With outputs over 300,000 pieces per hour, the IBM drills tablets precisely with ease. This flatbed machine comes with a bulk hopper and flood feeder for maximum fill rates and can drill one side of a tablet.

### Features

- Single sided laser drilling
- Adjustable hopper for maximum fill rate
- Servo drive system for precision print registration
- Quick change tooling
- Swingarm 15" touchscreen HMI
- Wi-Fi connectivity
- Batch recording
- 21 CFR Part 11 Compliant
- CE and UL certified

### Capabilities

- Output Up to 300,000 / Hour
- Single Sided Laser Drilling.
- Adjustable aperture:
  - Diameter - 0.400 to 1.500mm
  - Depth - 0.30 to 1.50mm
- Drill up to 4 apertures per side with adjustable spacing
- Color recognition system

### Options

- Vision inspection system with single piece rejection
- Validation document packages available
- Floor level infeed bulk conveyor

### Safety & Regulatory Compliance

- cGMP for Pharmaceuticals:
- FDA 21 CFR Compliance:
  - Part 210
  - Part 211
  - Part 11
- CE Compliant
- NFPA 79
- IEC / EN 60204-1
- ISO 13849-1
- CRC, c 870
- CDRH Compliant

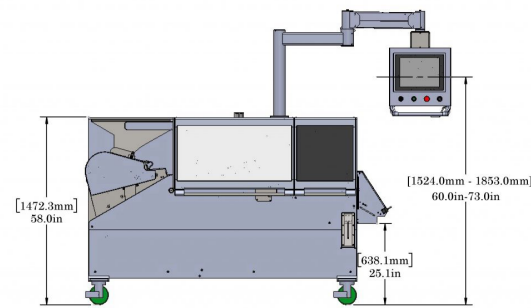
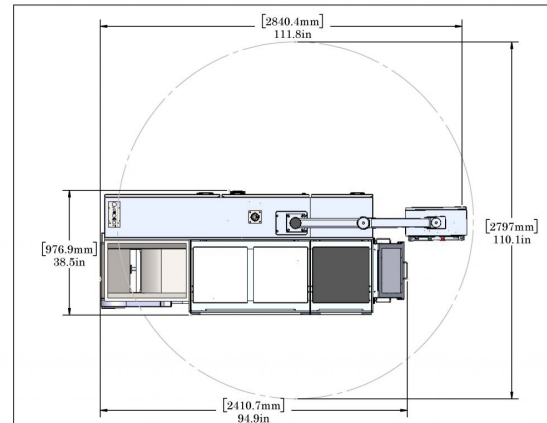

### Specifications

<b>H</b>	2314.4mm / 91.1in
<b>H1</b>	1480.3mm / 58.3in
<b>H2</b>	1524mm - 1853mm / 60.0in - 73.0in
<b>W1</b>	955.5mm / 37.6in
<b>W2</b>	2740.6mm / 107.9in
<b>L1</b>	2832.9mm / 111.5in
<b>L2</b>	2352.8mm / 92.6in
<b>POWER</b>	240 VAC / 30 amp / single phase
<b>AIR PSI</b>	Air 90 psi @ 5 scfm



Made in the USA