



ACKLEY HARTNETT



Ink Viscosity System

Addressing the challenges of ink drying and viscosity fluctuations, this innovative system revolutionizes tablet and capsule printing. By continuously mixing and recirculating ink while maintaining precise viscosity control, it significantly enhances print quality and reduces waste through effective containment, agitation, and automated oxidation response.

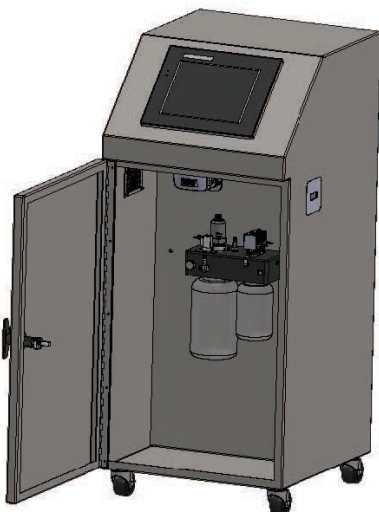

KEY BENEFITS

- **Improved Print Quality:** Maintains consistent ink viscosity, resulting in clearer, more precise logo transfers on tablets and capsules.
- **Extended Production Runs:** Enables longer batch processing times without compromising print quality, increasing overall productivity.
- **Reduced Ink Waste:** Efficient ink management through containment and recirculation minimizes waste and lowers material costs.
- **Temperature Adjustability:** Adjusts to accommodate varying temperature and environments, ensuring consistent performance in various conditions.
- **Enhanced Process Control:** Provides real-time viscosity monitoring and adjustment, allowing for better quality control and reduced supervision requirements.



This effortless and user-friendly system will maintain high ink quality for extended runs.

FLOOR PLAN

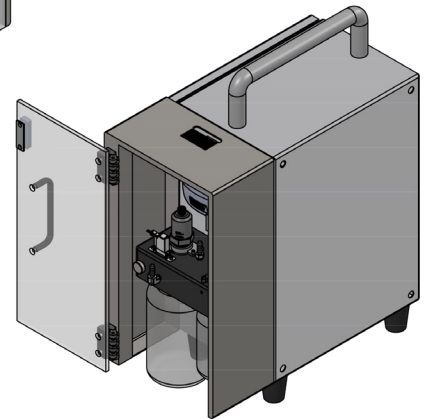
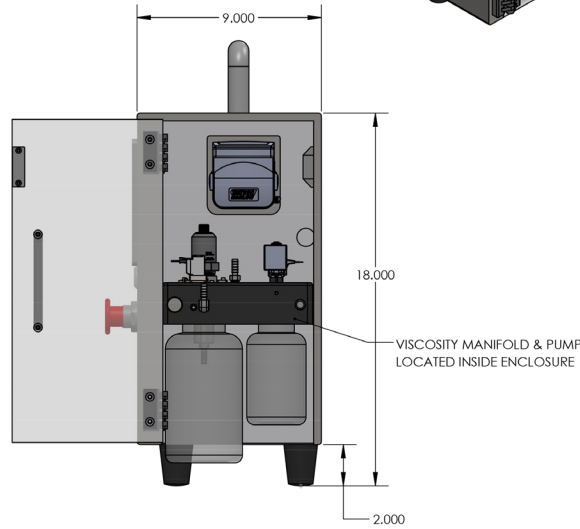
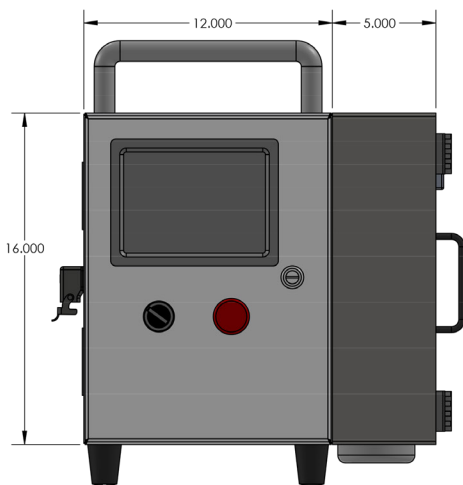
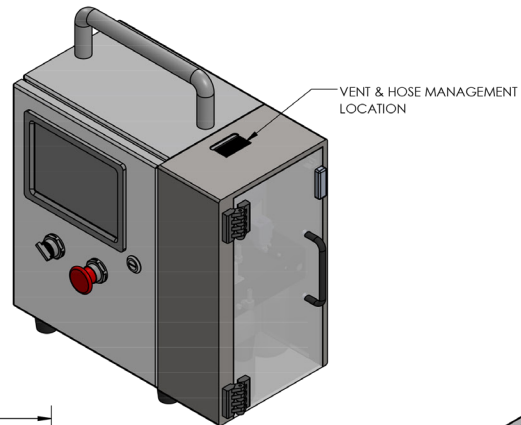
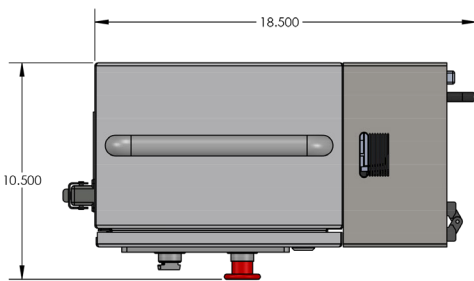

CONTACT US

ackleyhartnett.com
Phone: 215-969-9190 | Email: info@ackleyhartnett.com